

Theia

TECHNOLOGIES



The Theia ultra wide series of lenses are high quality precision optical lenses designed for megapixel class cameras using Theia Technologies' Linear Optical Technology. They offer ultra wide field of view with much lower barrel distortion than typical wide angle lenses. The optical distortion correction in the lens gives a crisp, sharp image from edge to edge.

Models

	Autoiris	Manual iris
CS-mount	SY125A	SY125M
C-mount	MY125A	MY125M

Notices and Safety information

- Do not look through the lens towards strong illumination such as the sun.
- The lens is a precision optical assembly and should not be subject to excessive vibration or shock.
- Do not disassemble the lens, there are no serviceable parts inside. If the lens requires service, see the warranty and return section.
- In some situations water vapor from the air may condense on the lens, such as rapidly moving from a cold place to a warm place. Avoid this condensation by letting the lens adjust to the ambient temperature before removing the lens caps or installing onto a camera.
- Do not touch the glass elements of the lens. To clean the lens, refer to the **routine service** section.
- Do not allow the lens to become wet.
- Do not use organic solvents on the lens such as thinner or acetone.

Installation and image inversion

Theia Technologies' Linear Optical Technology which allows the ultra wide angle lens to maintain very low distortion inverts the image. This requires the camera to be mounted upside down or the image to be inverted electronically.

Before installing the lens, make sure the lens is rotated fully towards the "near" focus position (fully rotated counterclockwise). Remove the lens caps and carefully screw the lens onto the camera. Tighten the lens against the camera mount. If the lens has an autoiris, plug the cable into the receptacle on the camera and use a dark neutral density filter in front of the lens to fully open the autoiris for focusing. If the lens has a manual iris, make sure it is fully opened by rotating the iris ring towards "open". Rotate the lens until the proper focus is achieved and tighten the thumb screw to lock the focus in place.

Iris operation

Manual iris lens

Adjust the iris opening by loosening the thumb screw near the front of the lens and rotating until the desired illumination is allowed through the lens. To allow more illumination, open the iris by rotating counterclockwise (looking at the front of the lens). Tighten the thumb screw to hold the iris in place.

Autoiris lens

The iris operation is controlled electronically by the camera with DC autoiris control. The autoiris cable should be connected to the camera's iris cable receptacle. Refer to your camera manufacturer's operators manual to set the camera's iris control to "DC autoiris".

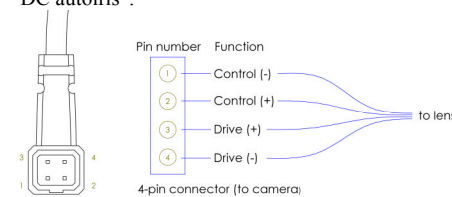

Routine service

Never touch the glass elements of the lens. Remove any dust or dirt accumulated on the lens with compressed air or a blower brush. To remove oil or fingerprints from the lens use a soft lint-free cloth or lens tissue dampened with alcohol or lens cleaning fluid. Wipe lightly in a spiral motion starting from the center of the glass element and working towards the edge. Repeat as necessary with a fresh area of cloth or lens cleaning tissue.

Specifications

Optical and mechanical

	1/4" (Ø4.5mm)	1/3" (Ø6.0mm)	1/2.5" (Ø7.2mm)	
Field of view	(H)	109°	125°	135°
	(V)	93°	109°	119°
	(D)	122°	137°	141°
Focal length	1.28mm			
F/#	F/1.8 to closed			
Resolution	Up to 3MPix			
Distortion (H)	<3% barrel (for 1/3" sensor)			
Minimum focus	1cm			
Pan-focus distance	10cm to ∞			
Lens size	Ø33mm x 59mm			
Lens weight	Approx. 100g			

The lens when used with a sensor greater than 1/2.5" will show dark corners.

Environmental

Operating temperature	-10°C to 50°C
Storage temperature	-20°C to 60°C
Relative humidity	5% to 80% (non-condensing)

Compliance

All products listed in this manual comply with applicable requirements for RoHS and CE marks. Compliance certificates are available by request from Theia Technologies.

Patents

Theia Technologies has multiple issued and pending US and international patents for lens technologies.

Contact information

Theia Technologies
29765 SW Town Center Loop W, Suite 4
Wilsonville, OR 97070 USA
Phone: 1-503-570-3296
Email: CustomerService@TheiaTech.com
Website: www.TheiaTech.com

SY125A / MY125A

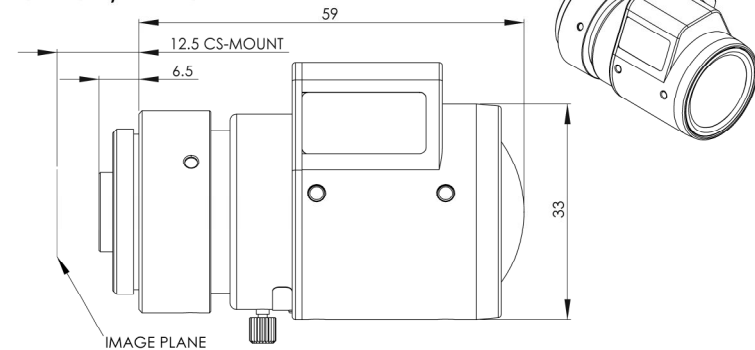

SY125M / MY125M

